

TECHNICAL HANDBOOK

Heavy Duty Slurry Pump

HD

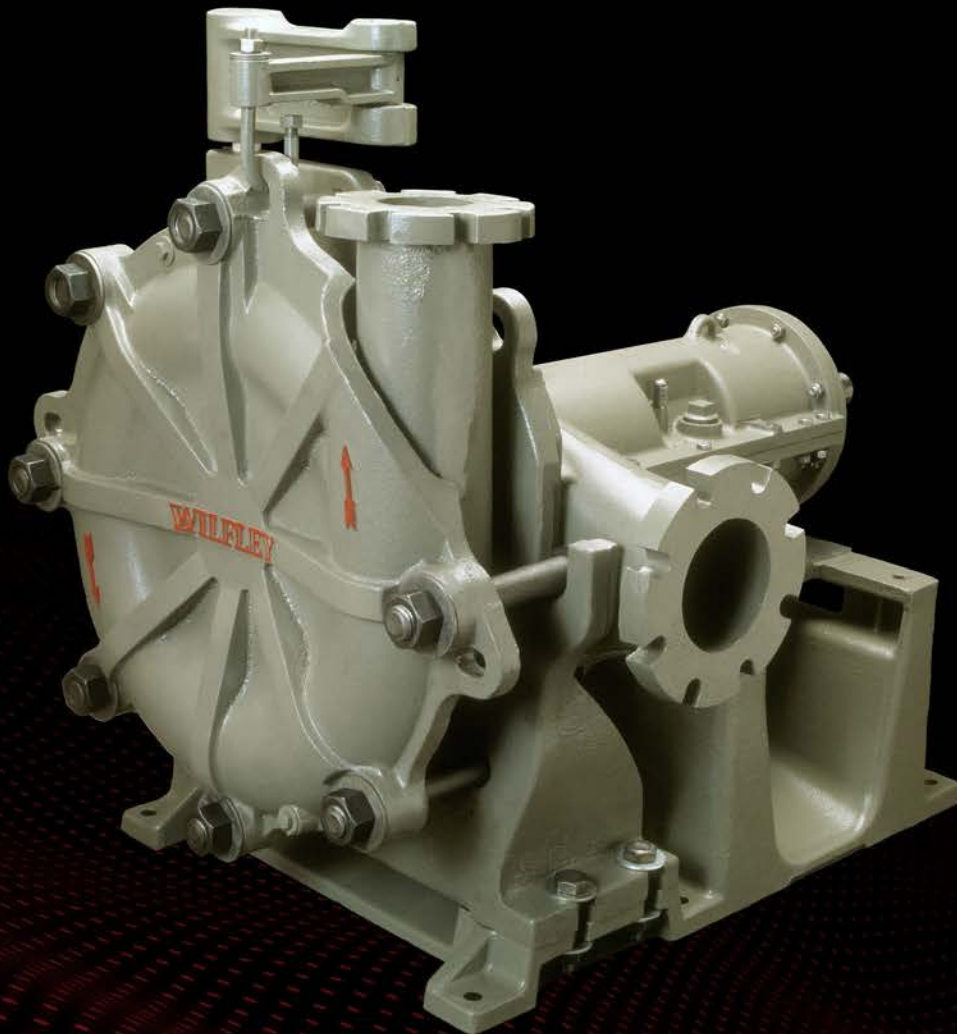

WILFLEY®



Wilfley Sealing
Technology



No Flush Water
Required

WILFLEY SEALING TECHNOLOGY

Wilfley Sealing Technology is the premier sealing solution for the toughest pumping applications and has proven to be a superior alternative to conventional sealing systems like mechanical seals and compression packing. It has been the foundation for every Wilfley pump design, dating back to the ground-breaking Model A slurry pump in 1919.

DYNAMIC & STATIC SEAL & SEAL

Wilfley Sealing Technology provides **leak free** operation at all times by partnering a dynamic seal (page 2) with a static seal (page 3). The dynamic seal prevents leakage while the pump is running and the static seal prevents leakage while the pump is off.

The harmony between the dynamic and static seal is what makes Wilfley Sealing Technology excel beyond conventional seals.



Wilfley Expellers

WILFLEY DYNAMIC EXPELLER SEAL

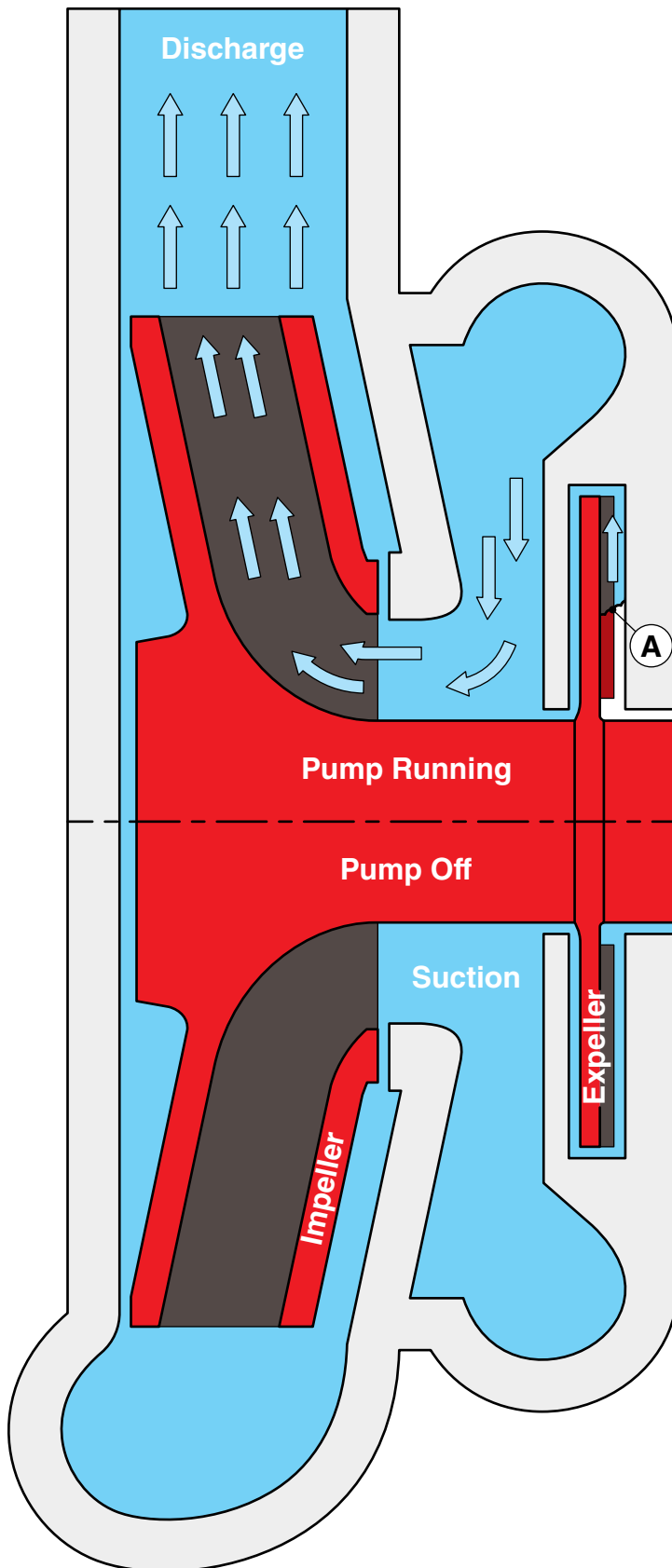

FEATURES & BENEFITS:

- A superior alternative to compression packing / mechanical seals and their associated flush systems
- Excellent solids / slurry handling capabilities
- Product dilution is eliminated
- Operational abuse tolerant, e.g. cavitation and vibration
- Reduces maintenance costs and maximizes production time through increased mean time between maintenance (MTBM)
- Exceptional dry running capability

HOW THE WILFLEY DYNAMIC EXPELLER SEAL WORKS:

- The positively-driven expeller has specially designed vanes that act directly on the pump fluid
- A liquid partition **(A)** is established during pump operation by centrifugal forces generated by the expeller
- This liquid partition effectively isolates the pump fluid from the shaft
- The governor-actuated SolidLock® static seal manages all fluid containment during idle conditions

WILFLEY SolidLock® STATIC SEAL



HOW THE SolidLock® SEAL WORKS:

At start up, the expeller (A) establishes a liquid interface that pulls the pumped fluid away from the seal faces. As this happens, centrifugal force moves weights (B) outwards to open seal faces (C) and prevent any rubbing contact.

At shut down, the liquid interface collapses and the pumped fluid is pushed towards the seal faces. Isolated springs (D) force the seal faces to close before any of the pump fluid can escape.

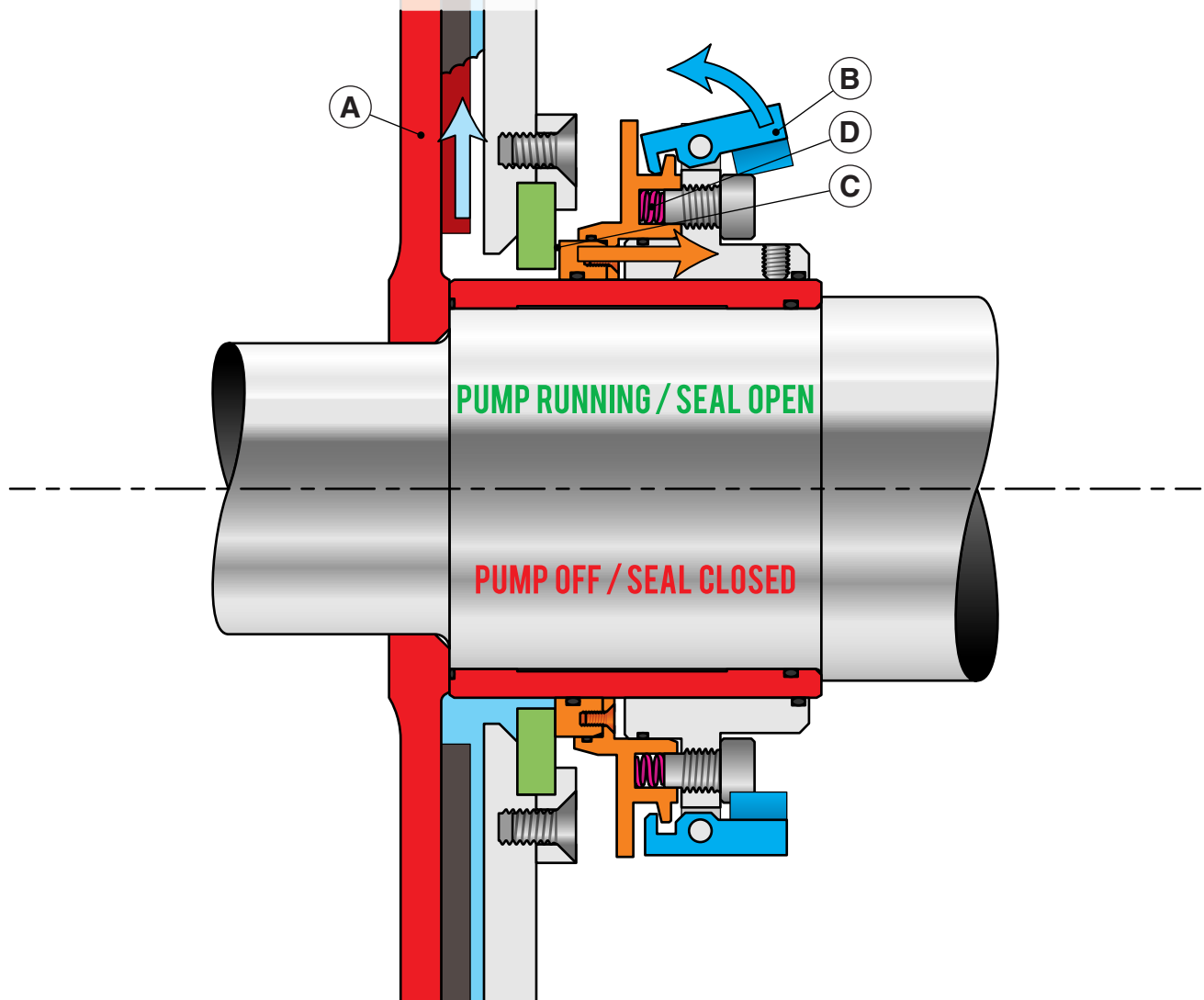

FEATURES & BENEFITS:

- **Leak free operation** - Precise and controlled opening and closing of the seal faces
- **Reliable and repeatable seal actuation** - The spring force is specifically set for your application and can be easily adjusted in the field if necessary
- **Easy to install / maintain** - Simple and effective design, no special tools needed

HD SLURRY PUMP SEALING OPTIONS

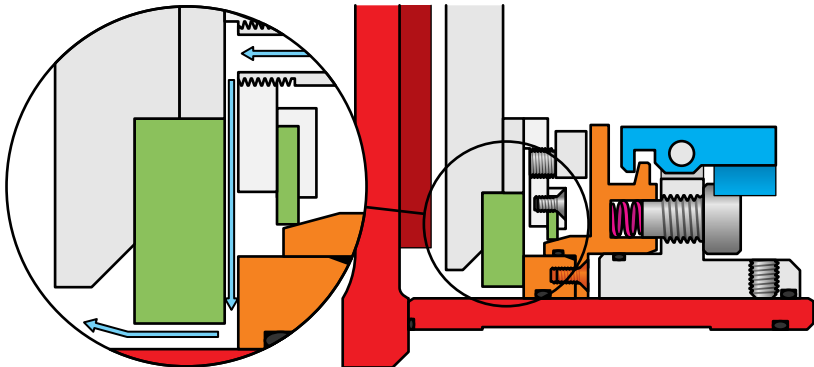

SolidLock™ with Flush Option
(Start up and / or Shut down)

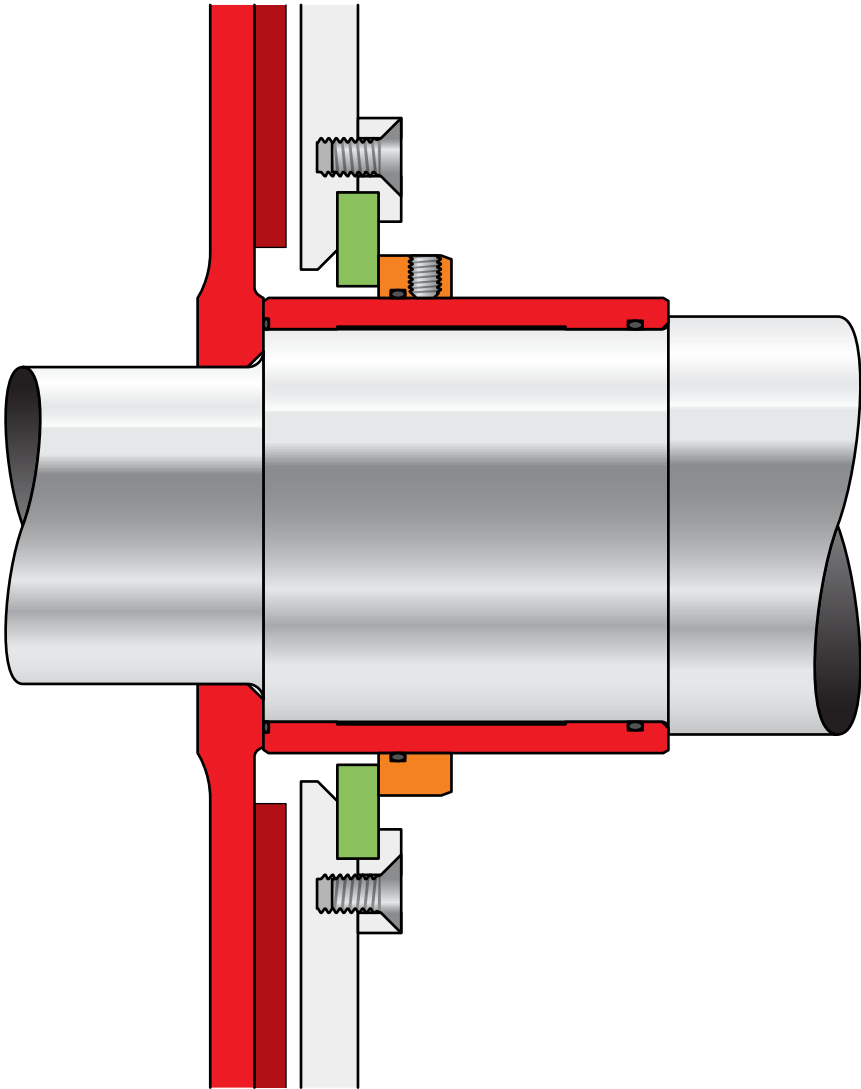

SolidLock™ Lite
(Diaphragm Seal with Expeller)

HD SLURRY PUMP FEATURES & BENEFITS

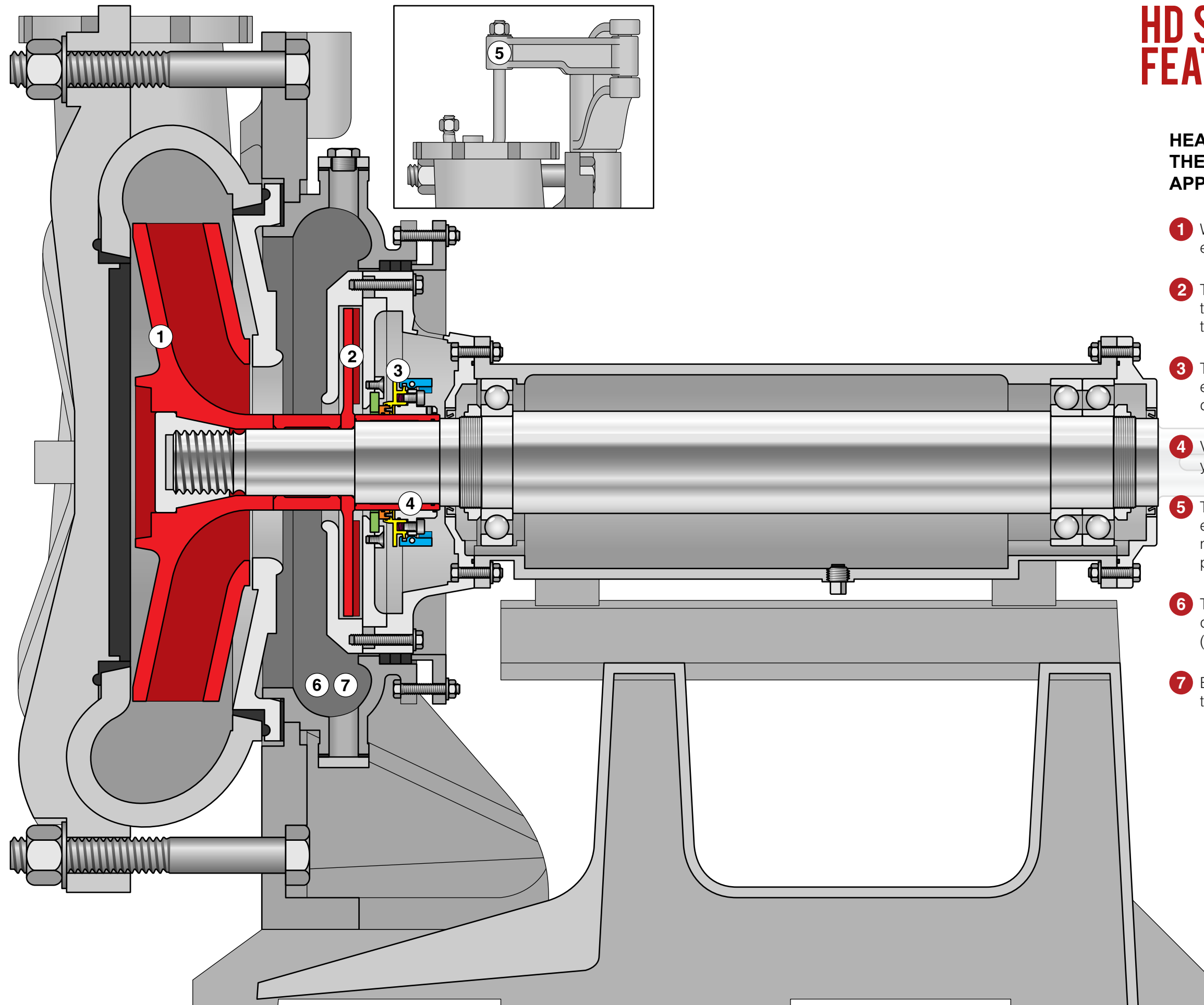

HEAVY DUTY CONSTRUCTION FOR THE TOUGHEST SLURRY APPLICATIONS

- 1 Wilfley's proprietary MAXALLOY® 5A provides extraordinary wear performance (see page 8)
- 2 The expeller has been optimized to provide the highest intake head sealing capability of the Wilfley slurry pump range (see page 2)
- 3 The SolidLock® static seal has been engineered for reliable leak free sealing during start up and shut down (see page 3)
- 4 Various sealing options are available to suit your specific needs (see page 4)
- 5 The unique side suction design allows for exceptionally easy serviceability without ever needing to disturb the suction or discharge piping (see page 7)
- 6 The side suction design optimizes the dynamic sealing capability of the expeller (see page 7)
- 7 Exceptional froth handling capability due to the side suction design

BENEFITS OF A SIDE SUCTION SLURRY PUMP

A MAINTENANCE ENGINEER'S DELIGHT

- Case can be easily removed without disturbing suction or discharge piping
- Crane assembly supports the full weight of the case during maintenance
- Simple serviceability greatly reduces downtime
- Suction piping can be located on either side of the pump for connection flexibility
- Optimizes pump footprint

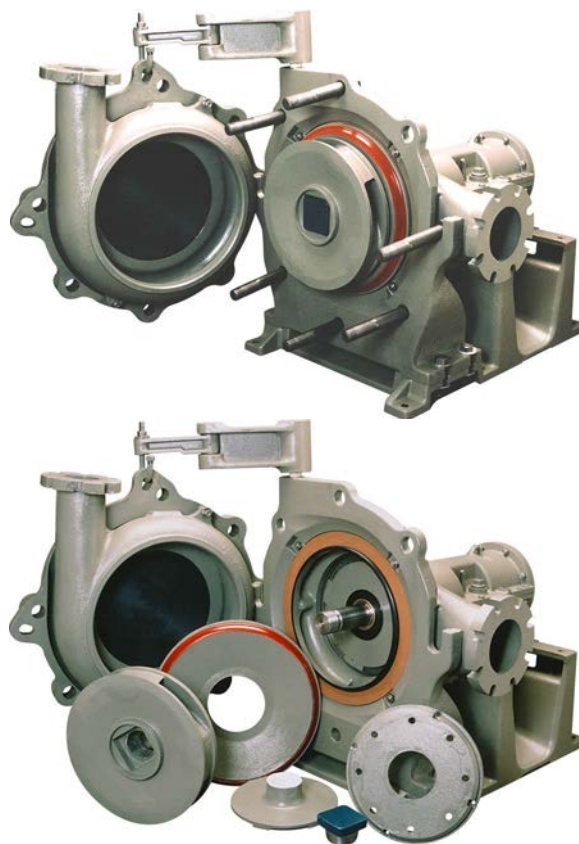

ENGINEERED AROUND THE WILFLEY DYNAMIC EXPELLER SEAL

The side suction design was originally developed by A.R. Wilfley to optimize the dynamic sealing capability of the expeller.

- The wet end is split into two chambers: the case (blue) and the intake chamber (green)
- The pressure in the intake chamber is significantly lower because it isn't affected by the discharge head
- The lower pressure makes it easier for the expeller to establish and maintain the liquid interface **(A)**
- This allows the Wilfley Dynamic Expeller Seal to hold back higher intake heads at lower speeds

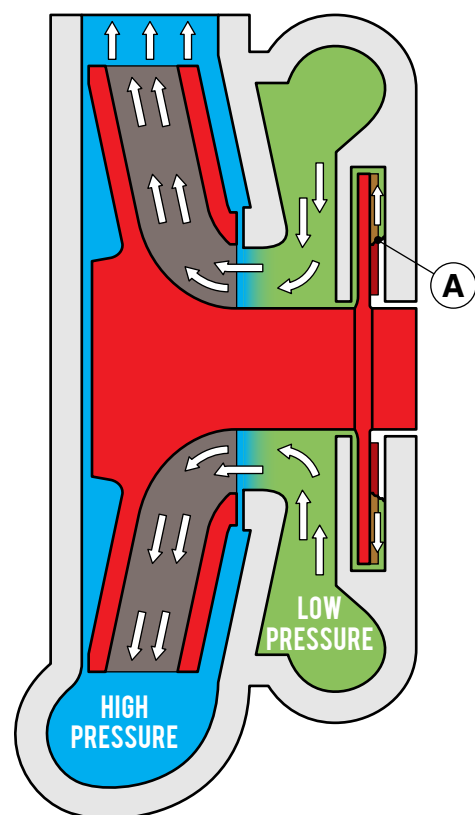

BREAKTHROUGH MATERIALS

Wilfley works discreetly with key suppliers, such as Western Foundries, to provide a variety of engineered metallurgies and proprietary processes for the longest possible pump and parts life and reliability.

WILFLEY KNOWS METALLURGY

This also allows Wilfley to provide very competitive lead times for both complete pumps and spare parts.

MAXALLOY® 5A

Wilfley's proprietary MAXALLOY® 5A was developed specifically for the toughest slurry applications, combining unsurpassed hardness for wear resistance with superior toughness for durability.

Through special proprietary processing, chromium carbides are evenly distributed in a fully martensitic matrix with an average hardness of **740 HBN**. The microstructure is designed to avoid any retained austenite, delta ferrite and secondary carbides resulting in extraordinary wear performance as compared to commonly available high chrome irons.

AVERAGE SERVICE LIFE

(Based on test field data)

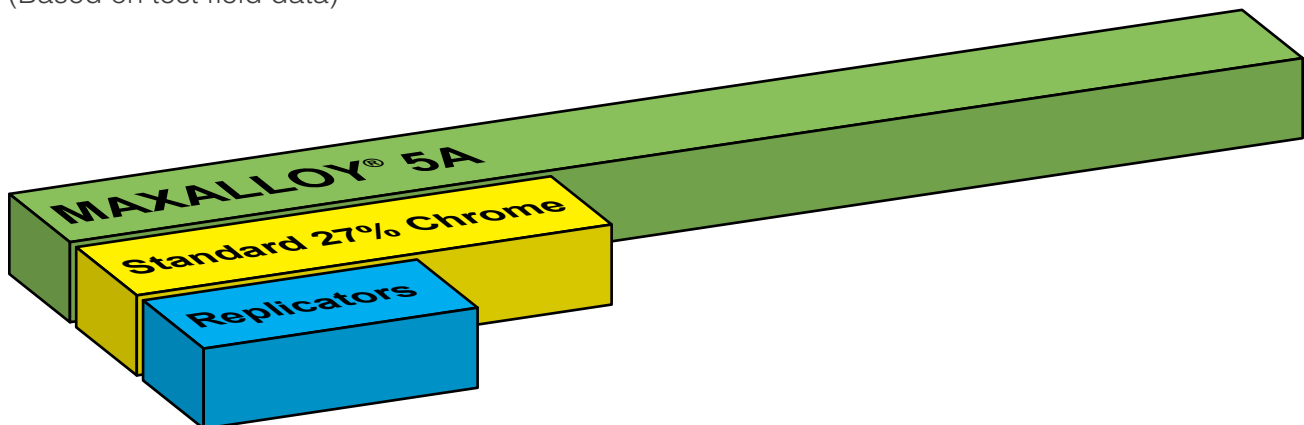

HD SLURRY PUMP CAPACITIES

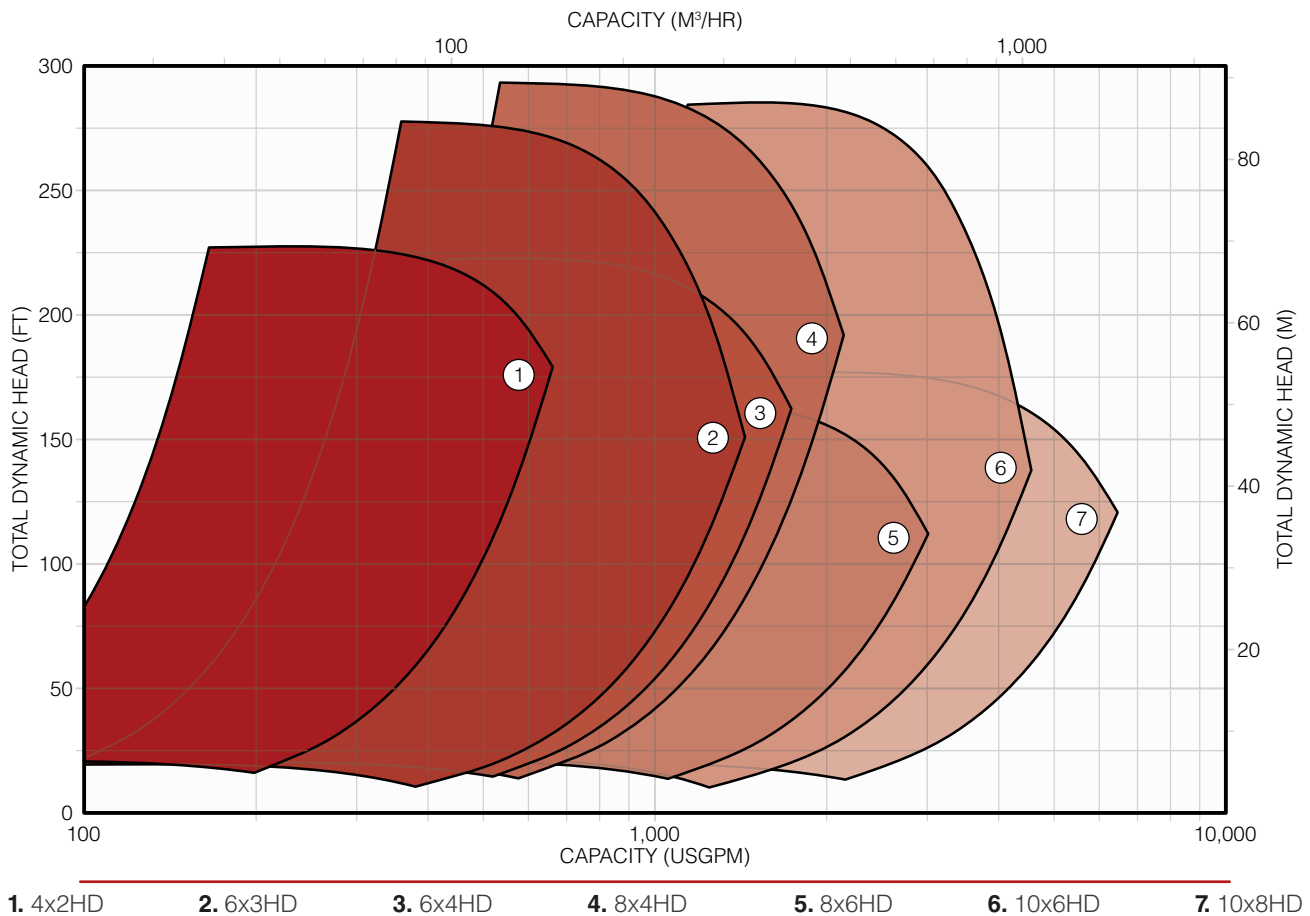

- 1. 4x2HD
- 2. 6x3HD
- 3. 6x4HD
- 4. 8x4HD
- 5. 8x6HD
- 6. 10x6HD
- 7. 10x8HD

CONSTRUCTION DETAILS

		4x2HD	6x3HD	6x4HD	8x4HD	8x6HD	10x6HD	10x8HD
GENERAL								
Bare Pump Weight	lbs	2,035	2,150	2,265	3,650	3,705	5,975	6,270
	kg	923	975	1,027	1,656	1,681	2,710	2,844
Max Passable Solids Size	in	0.3	0.5	0.75	0.75	1	1	1.4
	mm	8	13	19	19	25	25	36
SHAFT								
Diameter at Impeller	in	2.75	2.75	2.75	3.13	3.13	3.62	3.62
	mm	70	70	70	80	80	92	92
Diameter at Coupling	in	2.19	2.19	2.19	3.19	3.19	3.75	3.75
	mm	56	56	56	81	81	95	95
BEARINGS								
Radial		6320	6320	6320	6222	6222	6324	6324
Thrust		7320	7320	7320	7222	7222	7324	7324

DIMENSIONS

PUMP DIMENSIONS

Inches (Millimeters)

Pump Size	IN	OUT	C	D	F	FC*	FD*	G	J	K	M	N	P	Q	R	S	U	V	Z	AA	AC	PP	KEYWAY
4x2HD	4 (102)	2 (51)	36.5 (927)	13 (330)	1.5 (38)	-	-	14.5 (368)	21.13 (537)	16 (406)	8.31 (211)	19.13 (486)	28 (711)	1.13 (29)	0.75 (19)	6 (152)	0.81 (21)	8.25 (210)	26.5 (673)	6.5 (165)	2.19 (56)	65 (1651)	0.5 x 0.25 (13 x 6)
6x3HD	6 (152)	3 (76)	36.5 (927)	13 (330)	1.5 (38)	-	-	14.5 (368)	21.13 (537)	16 (406)	9.81 (249)	19.5 (495)	28 (711)	1.13 (29)	0.75 (19)	6 (152)	0.69 (17)	9.5 (241)	26.5 (673)	6.5 (165)	2.19 (56)	65 (1651)	0.5 x 0.25 (13 x 6)
6x4HD	6 (152)	4 (102)	36.5 (927)	13 (330)	1.5 (38)	-	-	14.5 (368)	21.13 (537)	16 (406)	10.5 (267)	19.5 (495)	28 (711)	1.13 (29)	0.75 (19)	6 (152)	1.44 (37)	11 (279)	26.5 (673)	6.5 (165)	2.19 (56)	65 (1651)	0.5 x 0.25 (13 x 6)
8x4HD	8 (203)	4 (102)	45 (1143)	14.25 (362)	1.5 (38)	15 (381)	9 (229)	25.5 (648)	25.63 (651)	21 (533)	12.25 (311)	23.5 (597)	30 (762)	1.25 (32)	0.75 (19)	7.38 (187)	3.13 (79)	15 (381)	31.5 (800)	8.44 (214)	3.19 (81)	53 (1346)	0.75 x 0.44 (19 x 11)
8x6HD	8 (203)	6 (152)	45 (1143)	14.25 (362)	1.5 (38)	15 (381)	9 (229)	25.5 (648)	25.63 (651)	21 (533)	13.06 (332)	23.5 (597)	30 (762)	1.25 (32)	0.75 (19)	7.38 (187)	4.19 (106)	17.13 (435)	31.5 (800)	8.44 (214)	3.19 (81)	53 (1346)	0.75 x 0.44 (19 x 11)
10x6HD	10 (254)	6 (152)	52 (1321)	17 (432)	2 (51)	18.88 (479)	11.5 (292)	31 (787)	31.63 (803)	24.5 (622)	15.94 (405)	30.5 (775)	38 (965)	1.75 (44)	1 (25)	7.75 (197)	3.63 (92)	19 (483)	33 (838)	9.38 (238)	3.75 (95)	84 (2134)	0.88 x 0.5 (22 x 13)
10x8HD	10 (254)	8 (203)	52 (1321)	17 (432)	2 (51)	18.88 (479)	11.5 (292)	31 (787)	31.63 (803)	24.5 (622)	15.63 (397)	30.5 (775)	38 (965)	1.75 (44)	1 (25)	7.75 (197)	5.13 (130)	22 (559)	33 (838)	9.38 (238)	3.75 (95)	84 (2134)	0.88 x 0.5 (22 x 13)

*Interior foundation bolt hole location

These dimensions are not for construction. Certified dimension prints are available for your specific installation

The suction can be located on either side of the pump to specifically meet your needs.

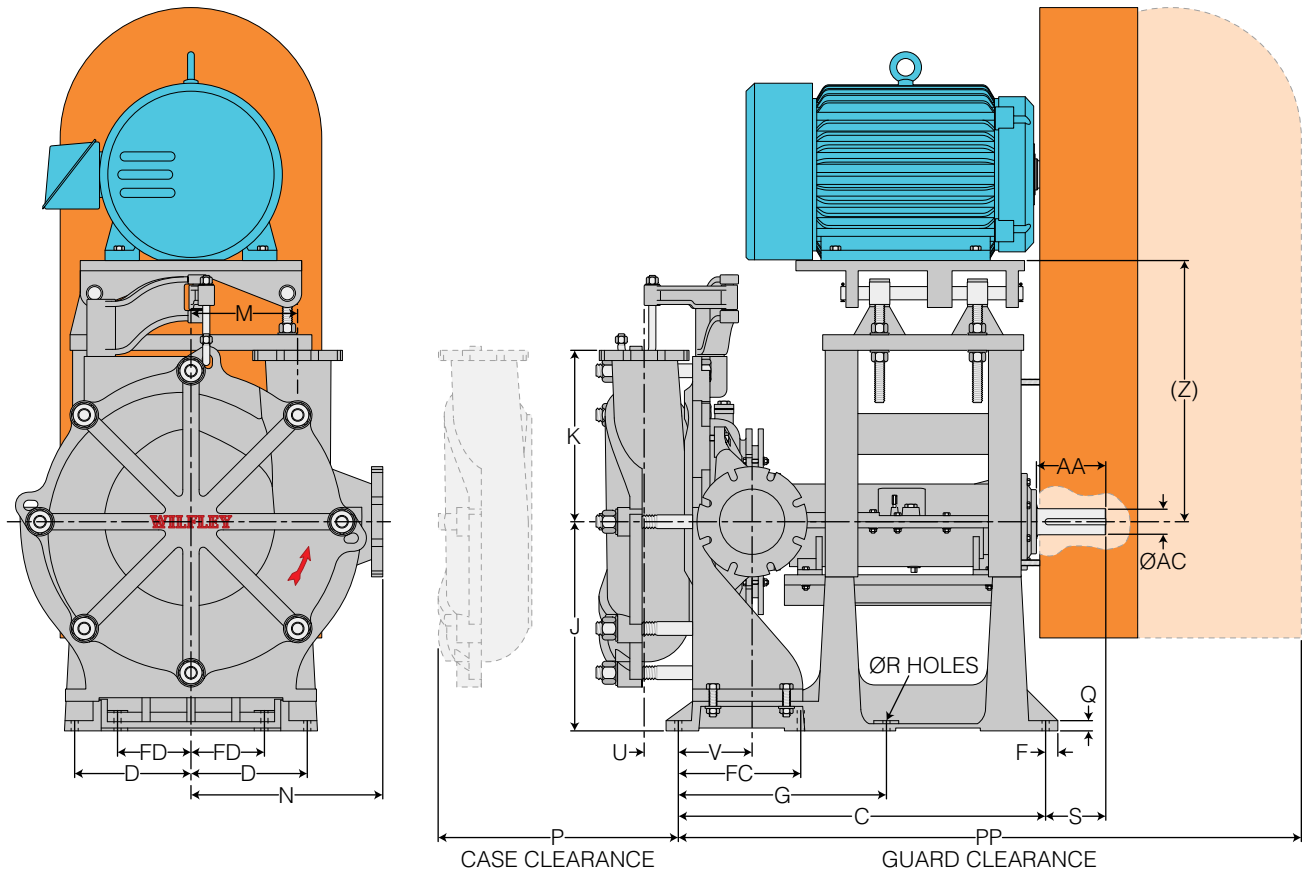

Direct drive configurations are also available. Contact Willey for more information.

VISIT WWW.WILFLEY.COM

to see our full range of pumping solutions



A9 Chemical Pump



EMW® Slurry Pump

WILFLEY®
HEAVY DUTY
CENTRIFUGAL PUMPS

5870 E. 56th Avenue, Commerce City, CO 80022, USA

Toll Free: 1-800-525-9930 • Telephone: +1 (303) 779-1777 • Fax: +1 (303) 779-1277

pumps@wilfley.com • www.wilfley.com