



Waste Heat Recovery Systems

Capturing existing waste energy

With the high cost and environmental impact of fossil fuels, heat energy is a precious commodity that cannot be wasted.

Any exhaust gas stream with temperatures above 250°F has the potential for significant waste heat recovery. Consumers of waste heat energy can be found in almost any facility and are easy to locate.

Typical examples include plant process heating, combustion air pre-heating, boiler feedwater pre-heating, and building heat. In addition to savings in everyday fuel consumption, many facilities can market and sell carbon credits back to industry. State and / or federal funding is often available for waste heat recovery projects helping to reduce capital costs and expedite system payback.

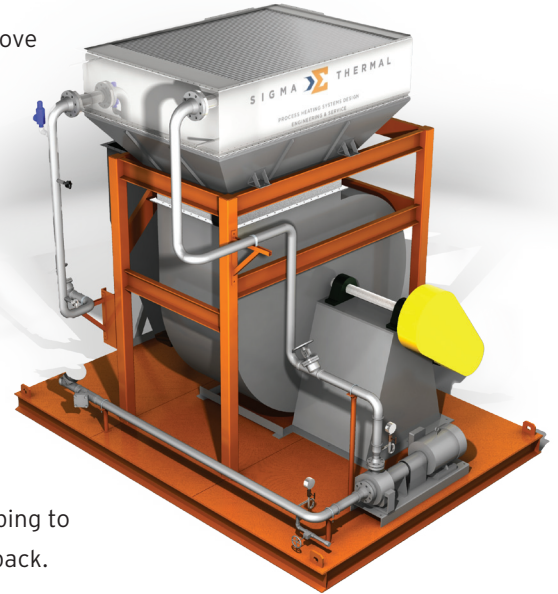

Heat Energy Recovery Audits

Sigma Thermal engineers are heat energy management experts. In addition to constantly optimizing our heating systems to provide the most cost effective operation possible, we provide energy audits and/or technical consulting to assist customers in determining if they have waste energy that can be recovered to further reduce their operating costs. If the audit results in recommendations for heat recovery equipment, we can provide that equipment and guarantee the energy savings, insuring that your recovery potential is fully realized.



Common Waste Heat Producers

- » Thermal Oxidizers
- » Steam Boilers
- » Fired Heaters
- » Kilns
- » Dryers
- » Exothermic Processes
- » Steam System Exhaust / Blow-down

Common Waste Heat Consumers

- » Combustion Air Pre-heat
- » Boiler Feedwater
- » Steam Ejectors
- » ORC Generators
- » Building Comfort Heat
- » Wash Water Pre-heat
- » General Process Heat

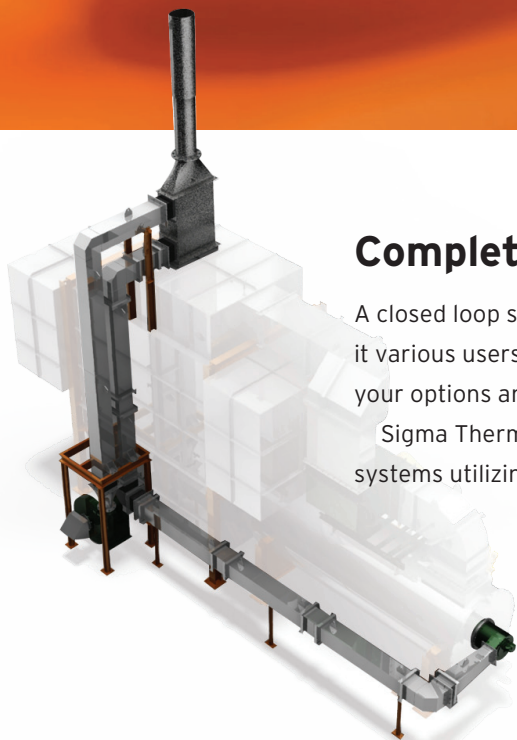

Complete Closed Loop Systems

A closed loop system is an efficient way of capturing wasted energy and transferring it various users. With experience in a broad range of transfer fluids, we can show you your options and design a system that best fits your needs.

Sigma Thermal offers complete closed loop, liquid phase, waste heat recovery systems utilizing water, glycol solutions and thermal oils.

Combustion Air Pre-Heat System (CAPH)

A combustion air pre-heat system increases overall system efficiency and minimizes system operating costs. Heater exhaust gasses are utilized to pre-heat the incoming combustion air. This is a more efficient utilization of the energy consumed, which results in lower natural gas operating costs. The estimated overall efficiency when using this system can exceed 93% (LHV basis). A typical summary of combustion air pre-heat system components is as follows:

- » Air to air heat exchanger
- » Modified burner to accommodate elevated combustion air temperatures
- » Combustion air ductwork from combustion fan to heat exchanger and from heat exchanger to heater
- » Exhaust gas ductwork from heater to heat exchanger, and from heat exchanger to stack (if applicable)

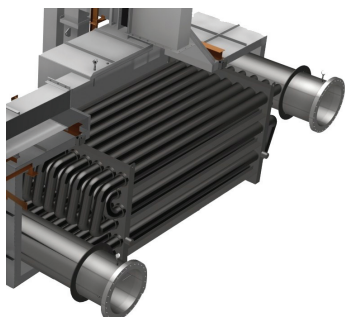
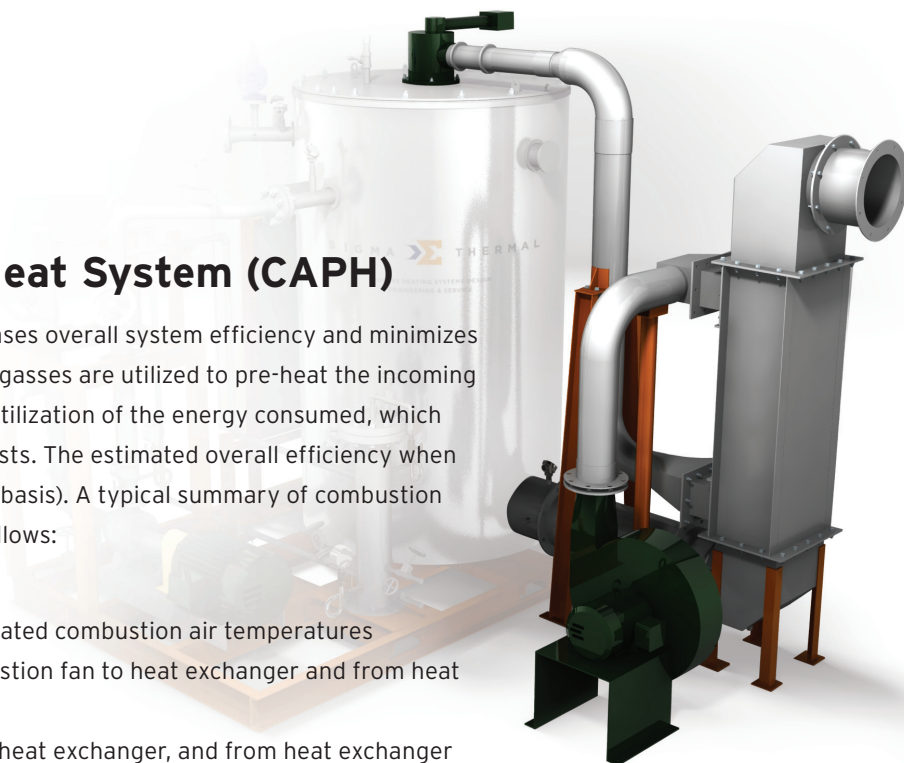

High Particulate Systems

Sigma Thermal specializes in biomass combustion and gasification systems, and has extensive design experience in capturing waste heat from high particulate exhaust gas. Once energy has been recovered from high particulate exhaust gas, it can be utilized with any traditional waste heat consumer.

