

SHAN-ROD

fabricated butterfly valves and dampers

BULLETIN 4300

Shan-Rod Fabricated **Butterfly Valves** 4300 Series

FLATE-O-SEAL™

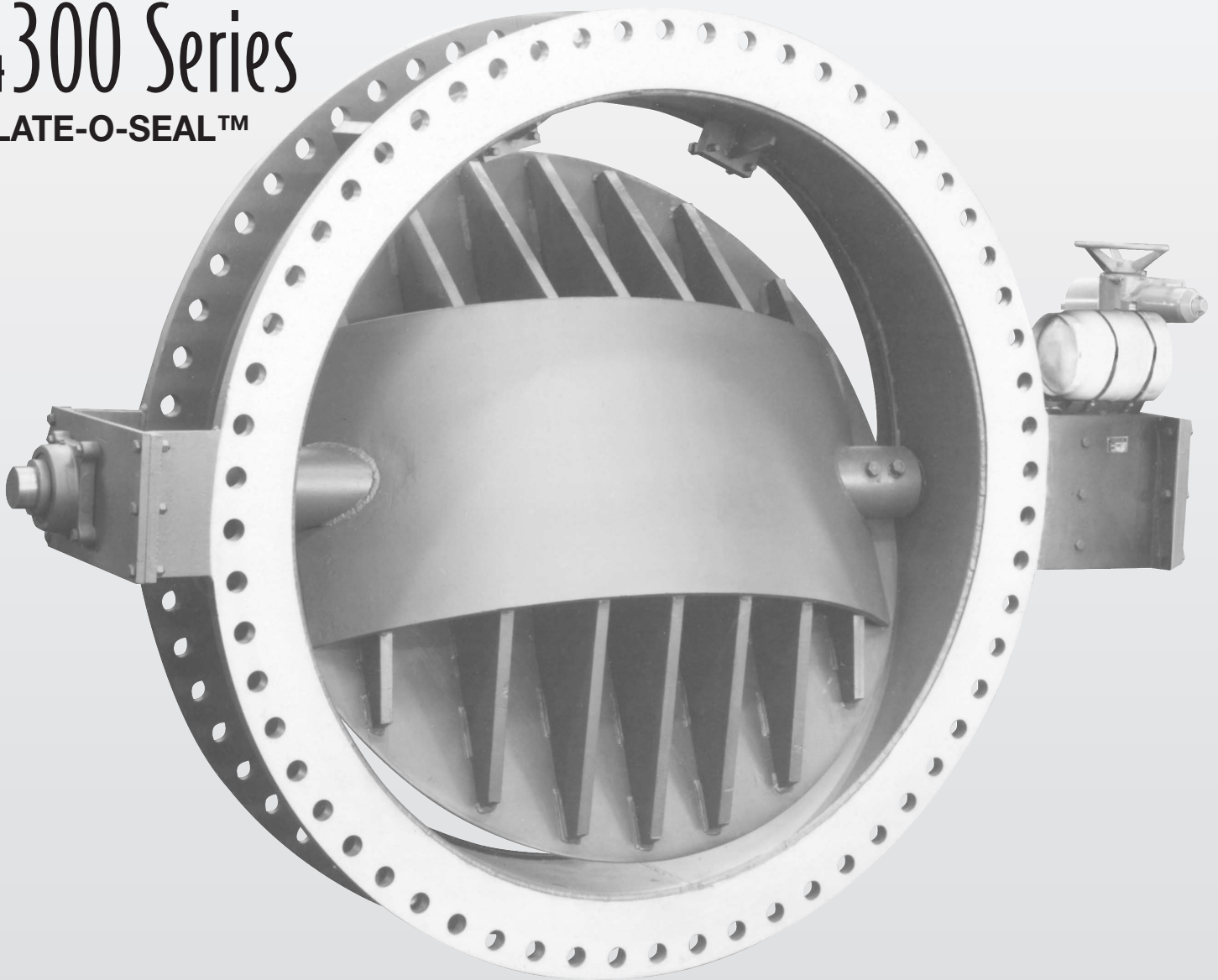

FEATURES

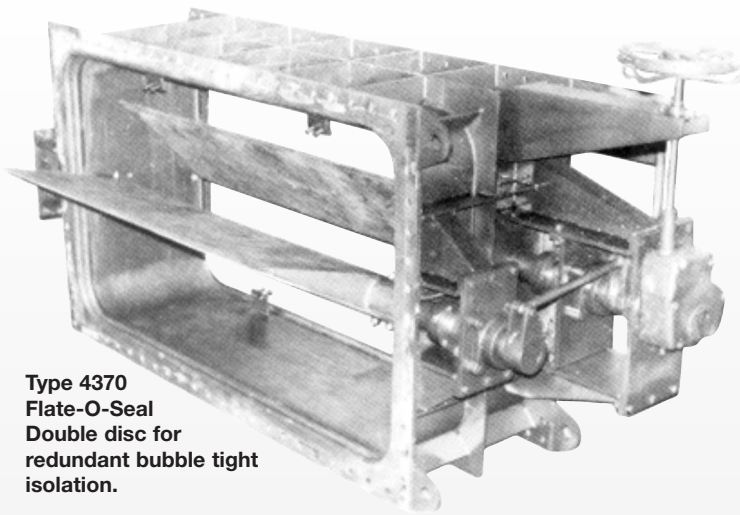

Type 4370
Plate-O-Seal
Double disc for
redundant bubble tight
isolation.

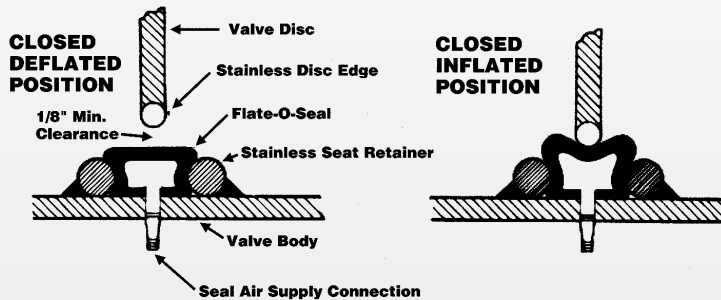

THE SHAN-ROD DAMPER

Shan-Rod fabricated butterfly dampers are designed to give long, trouble-free service in all pressure service applications. The versatility of fabricated dampers allows Shan-Rod to design the damper to your specifications as required by your systems.

DESCRIPTION

The basic valve consists of a fabricated carbon steel body, carbon steel disc with 304 stainless disc edge, plate flanges that conform to ductwork drilling and plate flanges for 125/150# ANSI drilling, 304 stainless stub shafts, taper pins, packing follower and studs, carbon inboard bushings, one outboard bearing (power end), graphite packing, packing follower and lubricated stuffing boxes and alemite purge fitting, inflatable elastomer seal.

The valve's inflatable seal encompasses the entire circumference of the disc when energized, and completely shuts off all flow. The valve is covered by U.S. patent number 3,840,208. An automatic or manual seal system using instrument air is furnished as an integral part of the valve and used in conjunction with a manual or automatic actuator. Shan-Rod engineers select the most compatible materials and elastomers for the service encountered in the chemical, refining, steel, paper and power industries.

1. **Bubble Tight Shut-Off**, with Combined Scissors/Inflatable Seat.
2. Double Disc for Redundant Bubble Tight Shut-Off (in event of seal damage).
3. Airfoil reinforced disc (optional).
4. Easy replacement of Seal on sizes 36" and larger without removing valve from the line.
5. Positive seal inflation when disc in closed position, and deflation before disc opening.
6. Bubble T.S.O. service.
7. Actuation available: Pneumatic, Electric, Hydraulic, Manual.
8. Engineered to suit system requirements in configuration, size face to face dimension, etc.
9. Nuclear safety and non-safety related application for Bubble Tight Shut-Off.
10. Lower Actuator Torque due to zero interference on opening and closing.

CONSTRUCTION AND MATERIALS

Construction	Standard	Optional
Flanges Body, Disc	Carbon steel	Corten, Al. Br., Aluminum 304, 316, 317, 309, 310 & RA 330 SS. Carpenter 20, Titanium, Tantalum, and any weldable alloy.
Shaft	304 SS	Alum., Al.-Br., 300 Series SS, 309, 310, RA-330 SS, Carp. 20, Titanium & Tantalum.
Bushings	Carbon	Gr. Br., 17-4 Ph, 300 Series SS, Stellite, Glass TFE filled.
Bearings (Outboard ball)	Power End	Ball & roller - all sizes
Packing Follower	304	Same alloys as body.
Lantern Gland	Carbon	Same alloys as body.
Seat	E.P.D.M. & Neoprene	Viton

OPERATING CONDITIONS

	Std.	Optional
Temp. °F.	300	400
Max. Static Press. (psig)	25	300
Shut-off Press. Drop (psi)	1	50

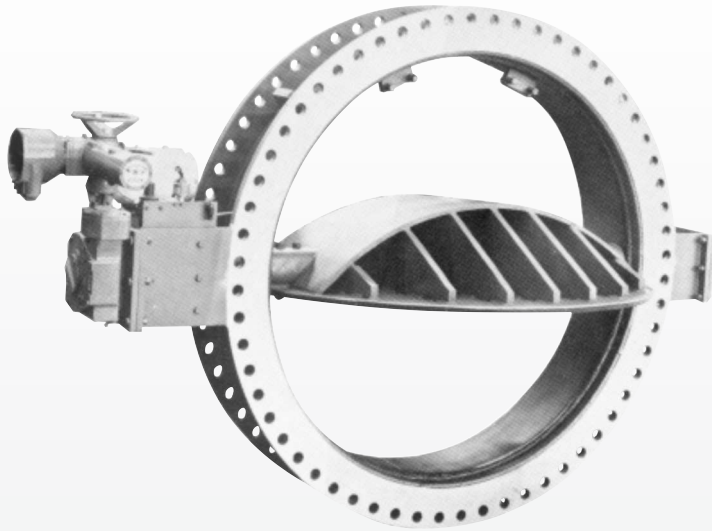

72" diameter blast furnace gas main header isolating valve
125# L.W. flanges actuator is Rotork electric.

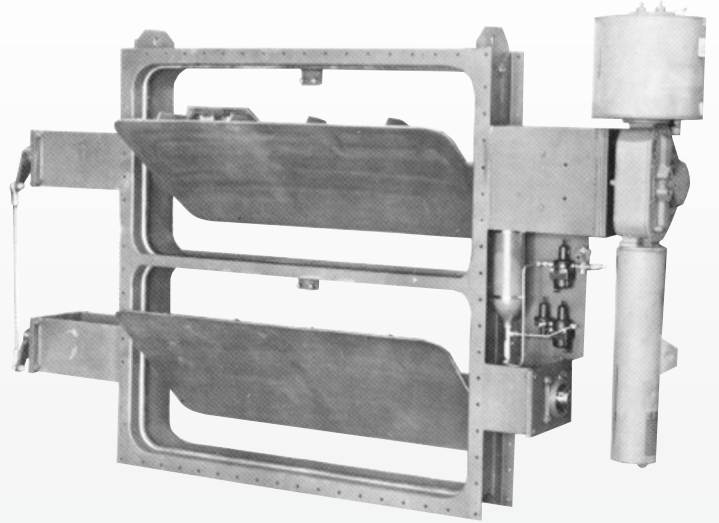

66" x 66" Type 4320 special vent isolation damper
ductwork drilling Bettis actuator.

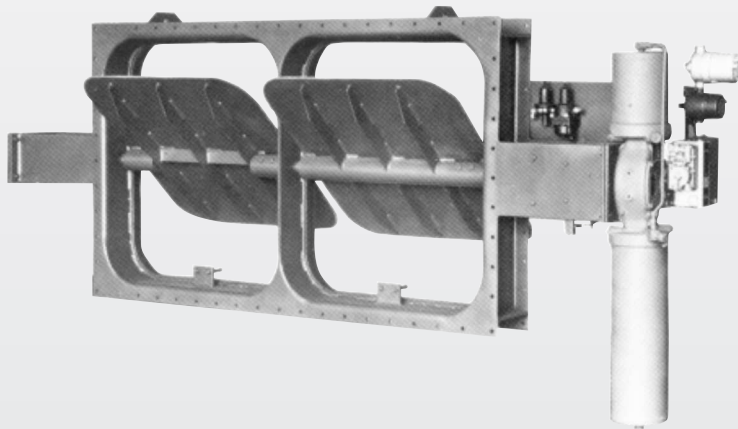

70" x 38" Type 4320 special vent isolation damper ductwork
drilling, Bettis actuator with Bailey positioner.

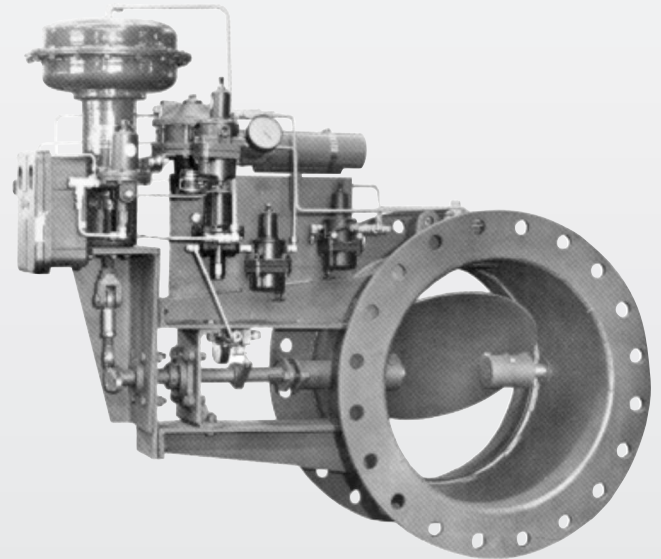

20" diameter coke oven gas isolation valve 25# AWWA
drilling, Fisher 4162R controller, and Fisher 656-40
actuator and Shan-Rod seal system shown.

Stuffing Box

Power End - Standard with carbon bushings requiring no lubrication for trouble free operation. Packing can be replaced without the removal of lever or actuator. It can also be furnished in stainless steel.

Blind End - Same as Power End except with no packing.

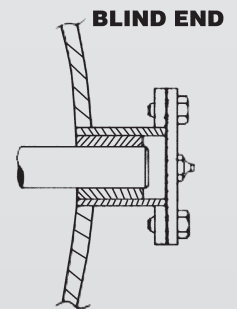
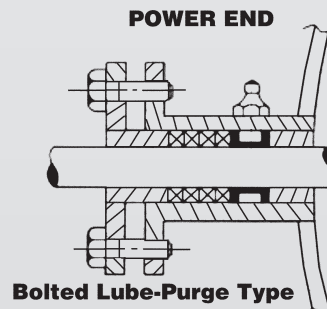
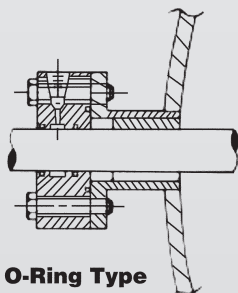

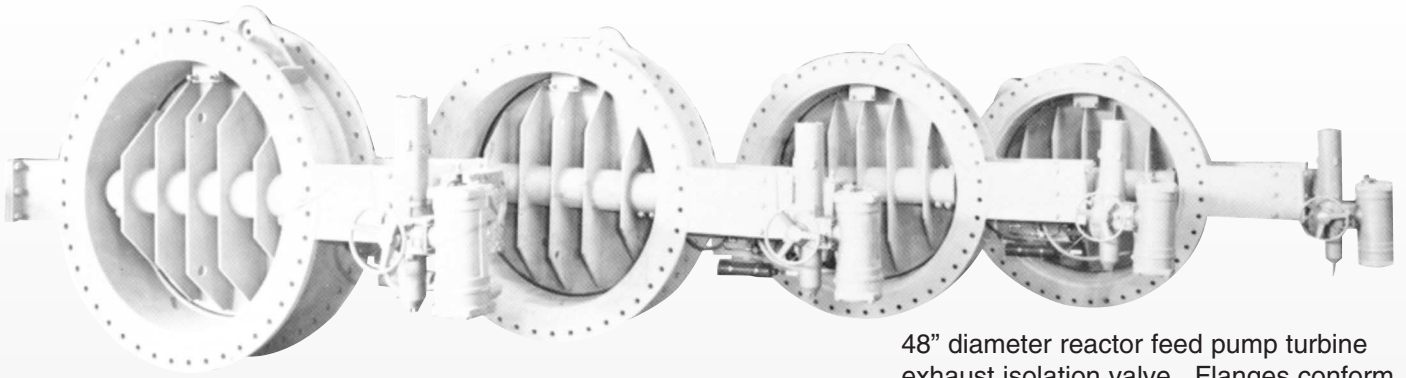

48" diameter reactor feed pump turbine exhaust isolation valve. Flanges conform to AWWA-C207 Class "B". Actuator is Rotork electric.

These valves have been supplied for bubble tight isolation in nuclear safety and non-safety related applications.

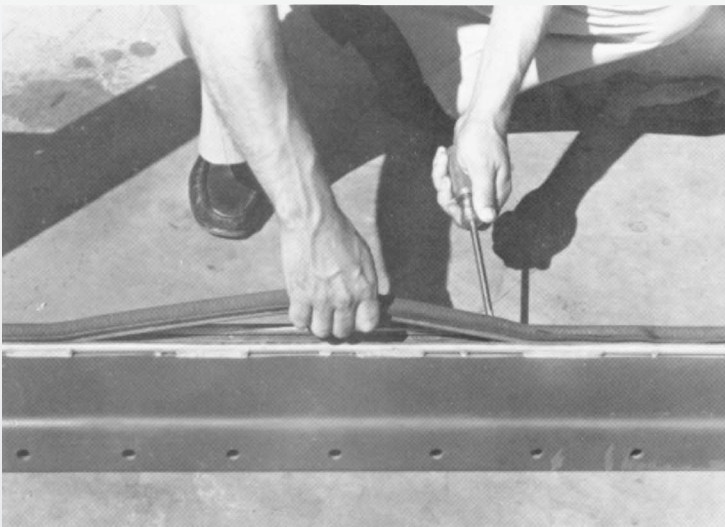

Seal Removal

Easily done with screwdriver and pulling with hand.

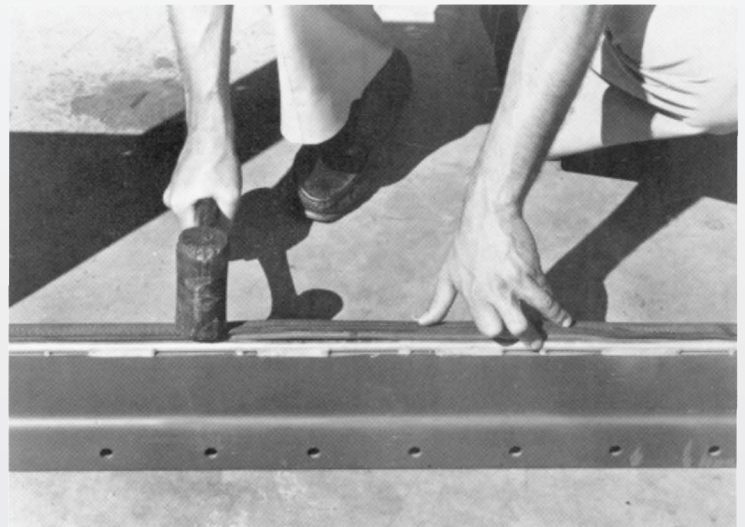

Replacing Seal

Easily done with rubber mallet.

SPECIFICATION GUIDE

When ordering specify: size, type of fluid, specific gravity, temperature, maximum pressure, maximum flow differential pressure at shut-off, valve action (fail open or fail closed), flange ratings, accessories, pipe run.

Other standard sizes available in increments of two inches, or valves can be custom made to customer specifications.

Do not use for construction purposes unless dimensions are approved.

Shaft may be vertical, if end of valve opposite power end is down (vertical thrust bearing or washer required).

MAINTENANCE

Shan-Rod valves require a minimum of maintenance, depending on service conditions. Stub shaft attached to disc with 304-SS taper pins allows easy shaft and disc removal. Inboard bushings do not require lubrication, thereby saving time. If service is dirty or corrosive, use of optional teflon bushings or outboard bearings is recommended. Lubricated and/or purged stuffing boxes should also be employed. All parts are easily replaced in field and, if required, are available from local sources since materials of construction are standard.

As we are continually developing our products, the design of Shan-Rod valves is subject to change without notice.

Sales Representative:

